

DRAWWIRE SENSOR

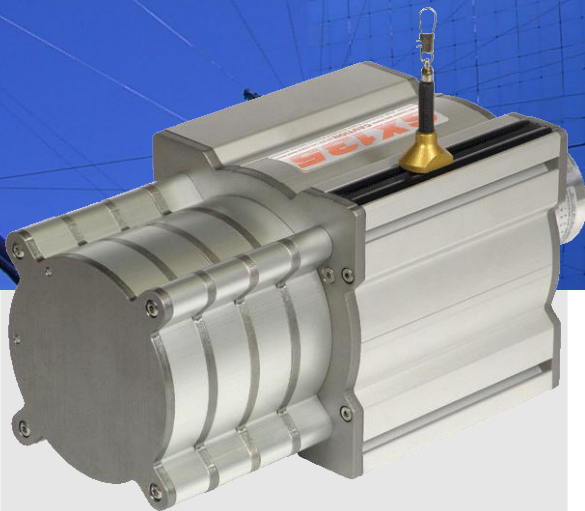
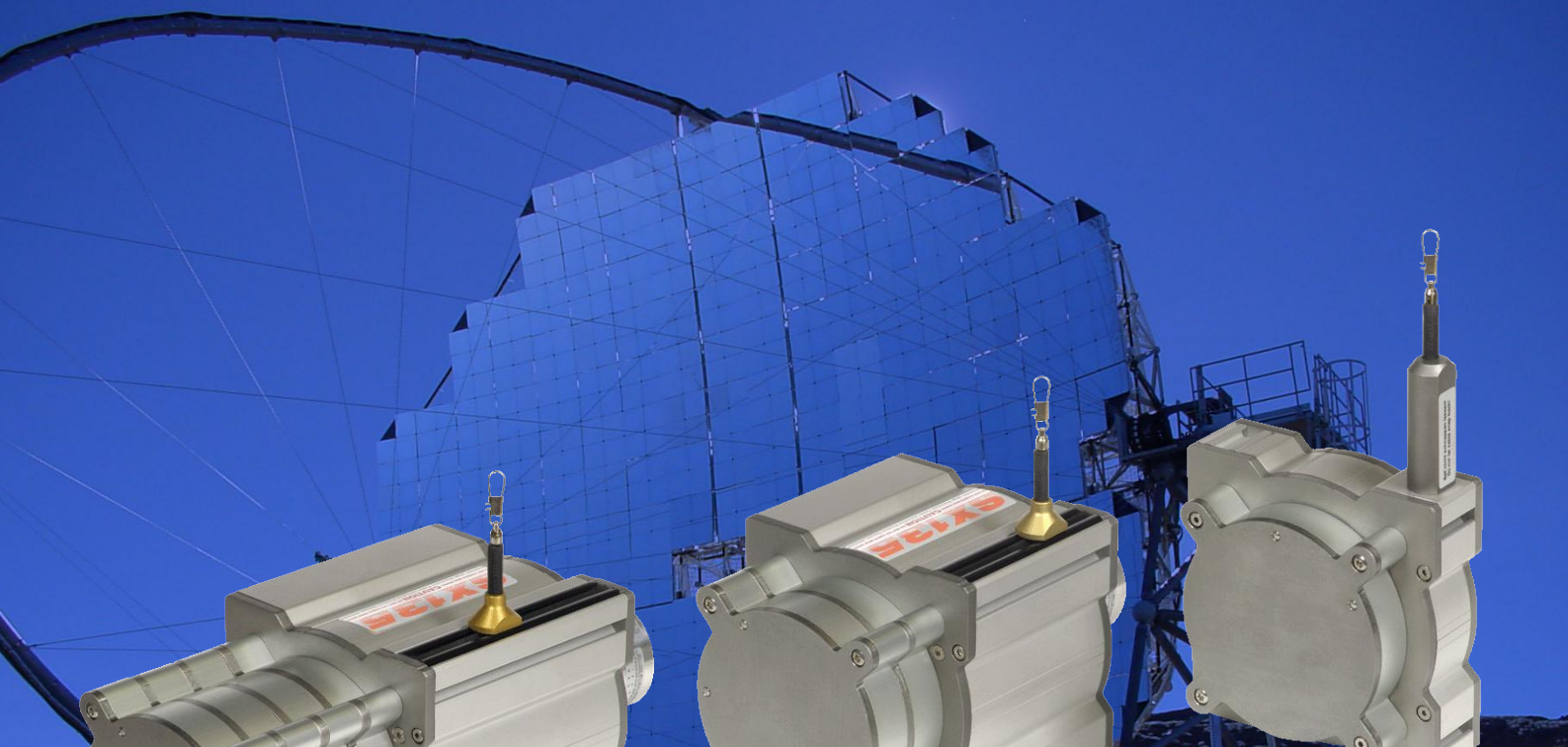

SX135 Long Range

Key-Features:

- Ranges 8000...42500 mm
- Analogue - Digital - Absolute - Bus
- Linearity up to 0,02 %
- Protection class up to IP67
- High dynamics
- High EMC-grade
- Customised versions available

Contents:

<i>Introduction - Applications</i>	<i>....2</i>
<i>Options</i>	<i>....3</i>
<i>SX135 up to 42,5 m</i>	<i>....4</i>
<i>Technical drawings</i>	<i>....5</i>
<i>Mounting / easy-clamp</i>	<i>....9</i>
<i>Analogue output</i>	<i>..10</i>
<i>Digital output</i>	<i>..11</i>
<i>Absolute output</i>	<i>..12</i>
<i>Accessories</i>	<i>..13</i>
<i>Installation - warning notices</i>	<i>..14</i>
<i>Order code</i>	<i>..15</i>

28.01.11

INTRODUCTION

WayCon Positionsmesstechnik GmbH is a manufacturer of high quality draw wire position transducers for industrial use. Due to its small overall size, its short assembly time and its possible customisation, the SX sensor technology is a cost-effective and flexible solution for a wide range of industrial applications. The dynamics of the draw wire transducer allows a high motion speed and acceleration of the measuring target. Its rugged design and high quality makes applications in harsh industrial environments possible. Special instruments are available with mounting service of encoder on site, as well as customised versions of housing.

Sensor principle:

A constant spring force coils the measuring rope accurately, single-layered on an ultralight rope capstan, so that its linear motion is converted into rotation. The sensor element (encoder) provides the output signal required.

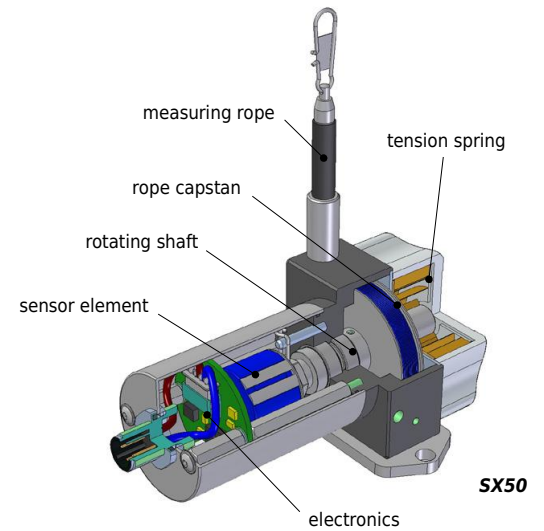

OUTLINE

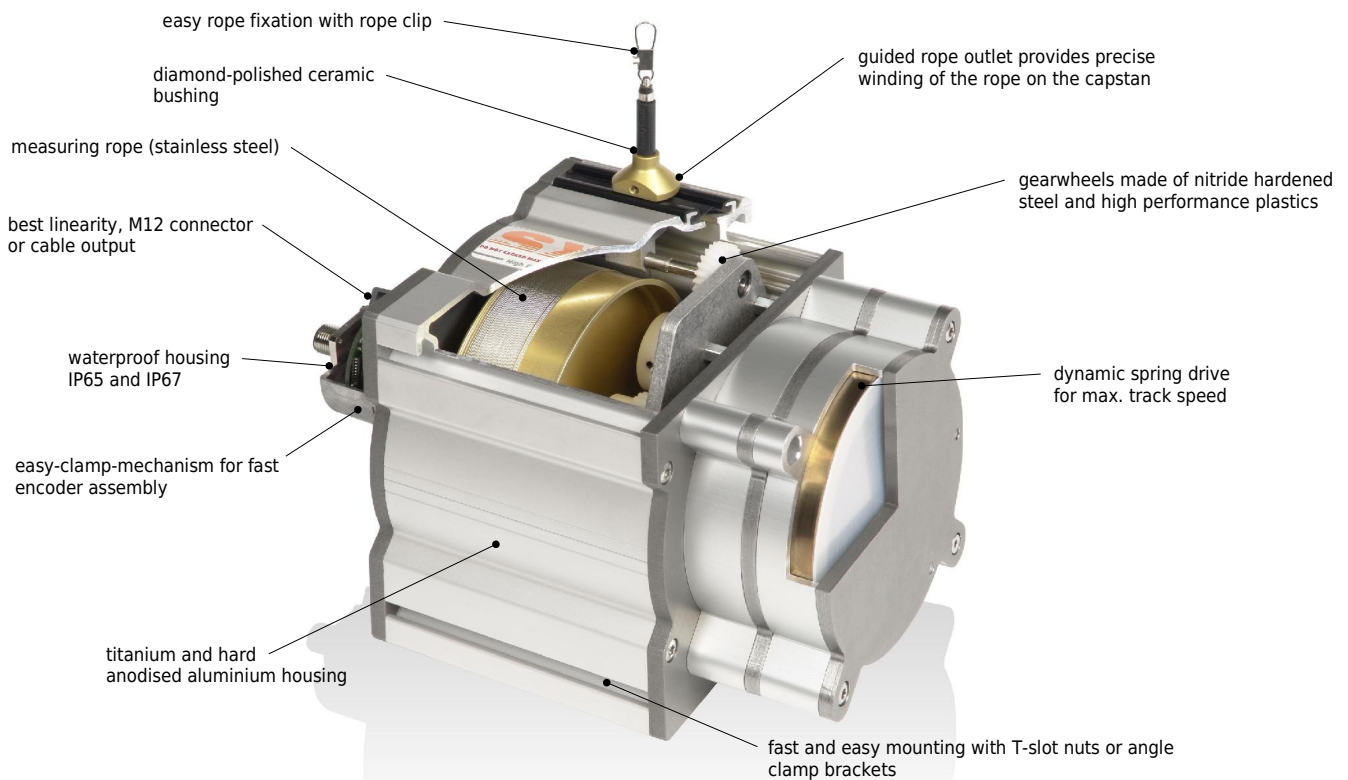

APPLICATIONS

- lifting tables and platforms
- positioning of fork-lifts
- level control system
- portal frames and gantry cranes
- lifting and rescue technology
- hydraulic cylinder
- property management
- linear guides
- x-y-axis positioning
- pipe displacement

OPTIONS

CO / ICP

CO: By the use of a special technology all components of the housing and the inner mechanics become HARTCOAT® coated. This coating is a hartanodic oxidation that protects the sensor from corrosion by aggressive media (e. g. sea water) with a hard ceramics-like layer.

ICP: This version combines the options CO (HARTCOAT®-coating) and IP67 (protection class IP67). In addition, a increased corrosive protection is achieved by the use of special components.

IN

The analogue signal of the sensor is increasing by extracting the rope (standard). Option IN inverts the signal, i. e. the signal of the sensor declines by extracting the rope.

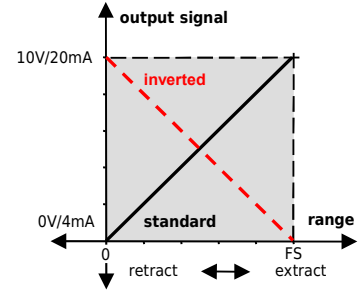

L05 / L02

Improved linearity on 0,05 % of measuring range. Resolution, repeatability and sensibility remain unchanged.

Improved linearity on 0,02 % of measuring range. Resolution, repeatability and sensibility remain unchanged. This option is only available for incremental sensors.

IP67

Use option IP67, if sensor is fully immersed in water (temporarily). Note that with this option there may occur a light hysteresis in the output signal due to the special sealing. The max. acceleration is reduced to 60 % of the specified value.

M4 rope fixation

Optional rope fixation with screw thread M4.
Ideal for attachment to through holes or thread holes M4.

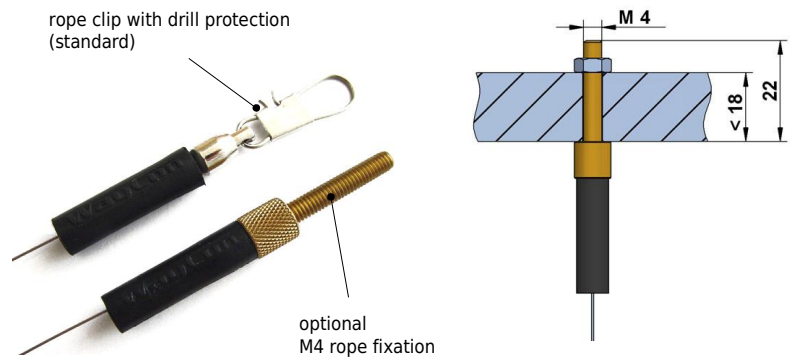

SERIES SX135



output	analogue potentiometer/ 0...10 V/ 4...20 mA (page 10)	digital output / digital-absolute / bus systems A/B-pulse, 90° phase-delayed (page 11-12)
sensor element	hybrid potentiometer	incremental encoder/ optical code disc
connection	M12-connector or cable output	connector or cable output
protection class	IP65, optional IP67	IP65, optional IP67
humidity	max. 90 % relative, not condensating	max. 90 % relative, not condensating
weight	approx. 4200 g	approx. 4200 g
housing	aluminium, titanium-grey and hard anodised	aluminium, titanium-grey and hard anodised

Technical data - analogue output

ranges [m] *	8	10	12	15	20	25	30	35	40	42,5
linearity [%]	0,10	0,10	0,10	0,10	0,10	0,10	0,10	0,10	0,10	0,10
linearity optional [%]	0,05	0,05	0,05	0,05	0,05	0,05	0,05	0,05	0,05	0,05

Technical data - digital output

ranges [mm] *	8	10	12	15	20	25	30	35	40	42,5
linearity [%]	0,05, independent from measurement range									
linearity optional [%]	0,02, independent from measurement range									
available resolution, range 8 m [pulses/ mm]	0,28	1,4	2,8	5,6	14					
available resolution, range 10 - 42,5 m [pulses/ mm]	0,3	1,5	3	6	15					
Z-pulse-distance, range 8 m [mm]	357,14									
Z-pulse-distance, range 10 - 42,5 m [mm]	333,33									

* other measurement ranges on request

Mechanical data

range [m]	rope tension		velocity	acceleration*
	F_{min} [N]	F_{max} [N]	V_{max} [m/s]	a_{max} [m/s ²]
8	7,2	16,0	10,0	140
10 / 12 / 15	8,7	16,9	6,0	80
20	7,0	12,4	5,0	60
25 / 30	7,3	15,7	5,0	60
40 / 42,5	7,0	14,1	5,0	60

* reduced to 60 % with option IP67

TECHNICAL DRAWING

8 m range, analogue output

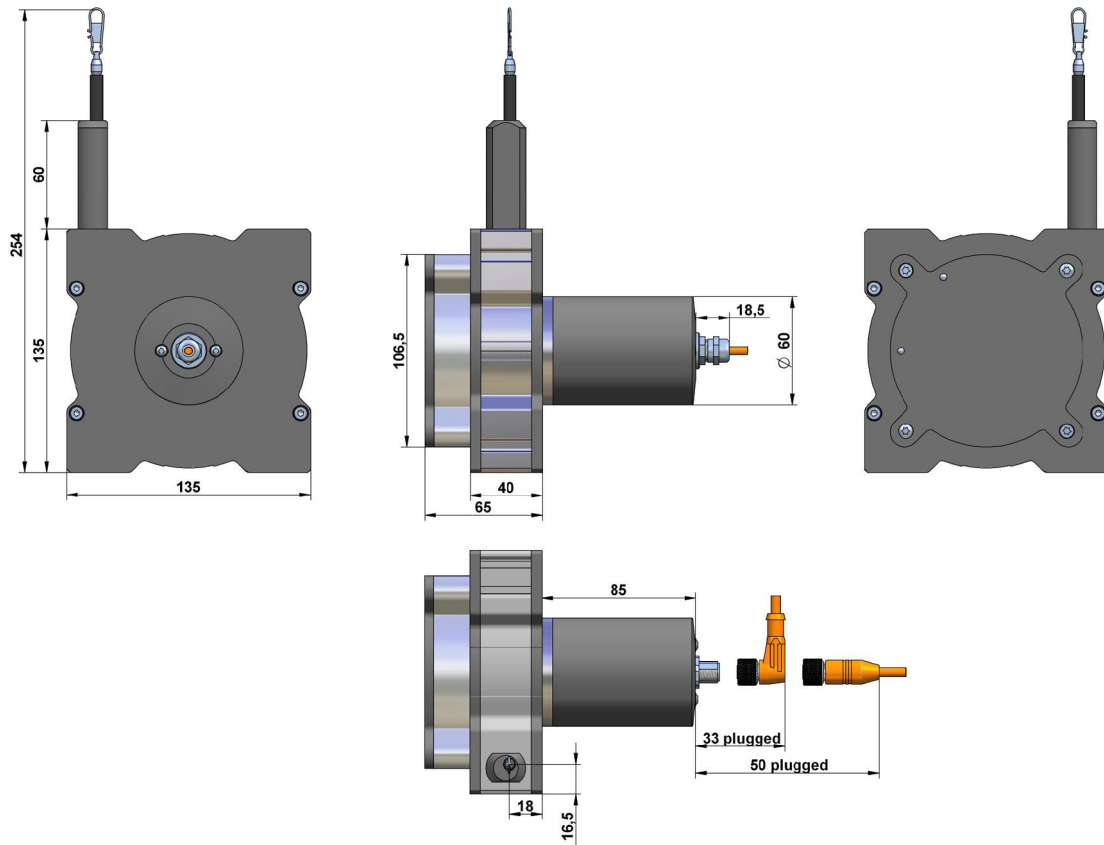

8 m range, digital output

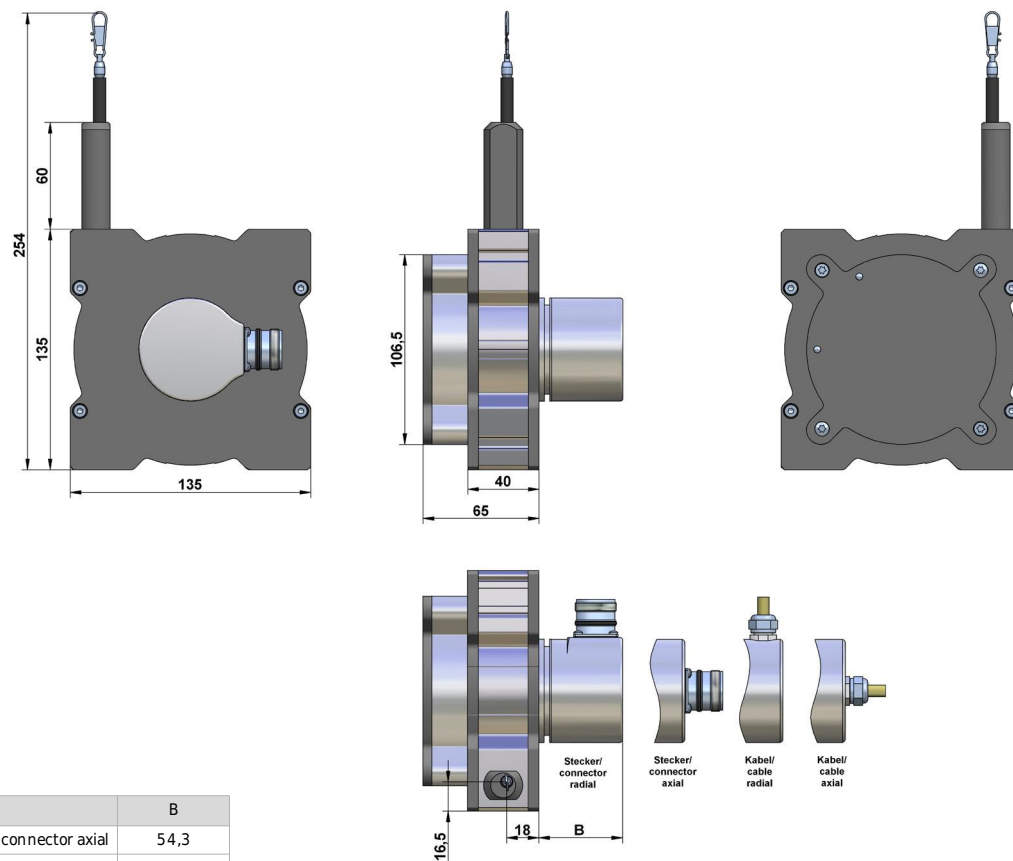

output	B
cable axial/ radial, connector axial	54,3
connector radial	64,3

TECHNICAL DRAWING

10 - 12 m range

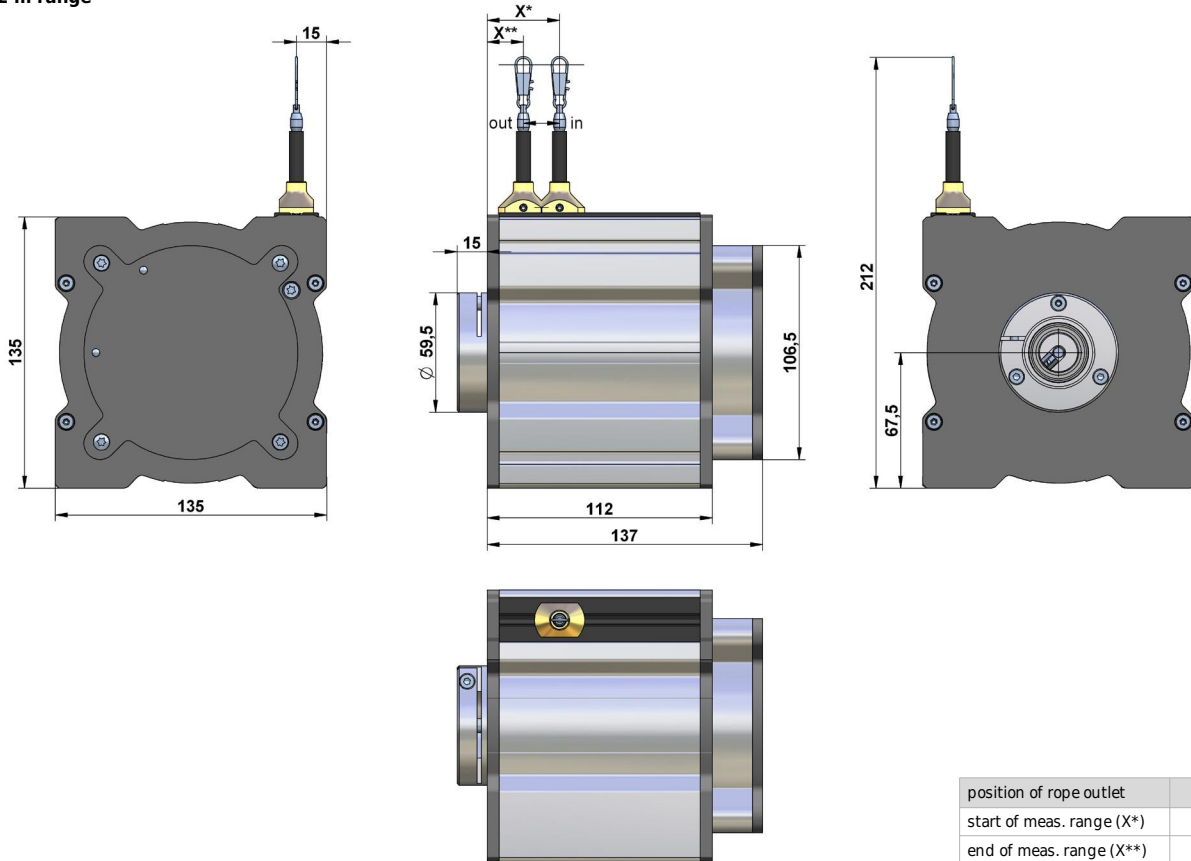

15 - 20 m range

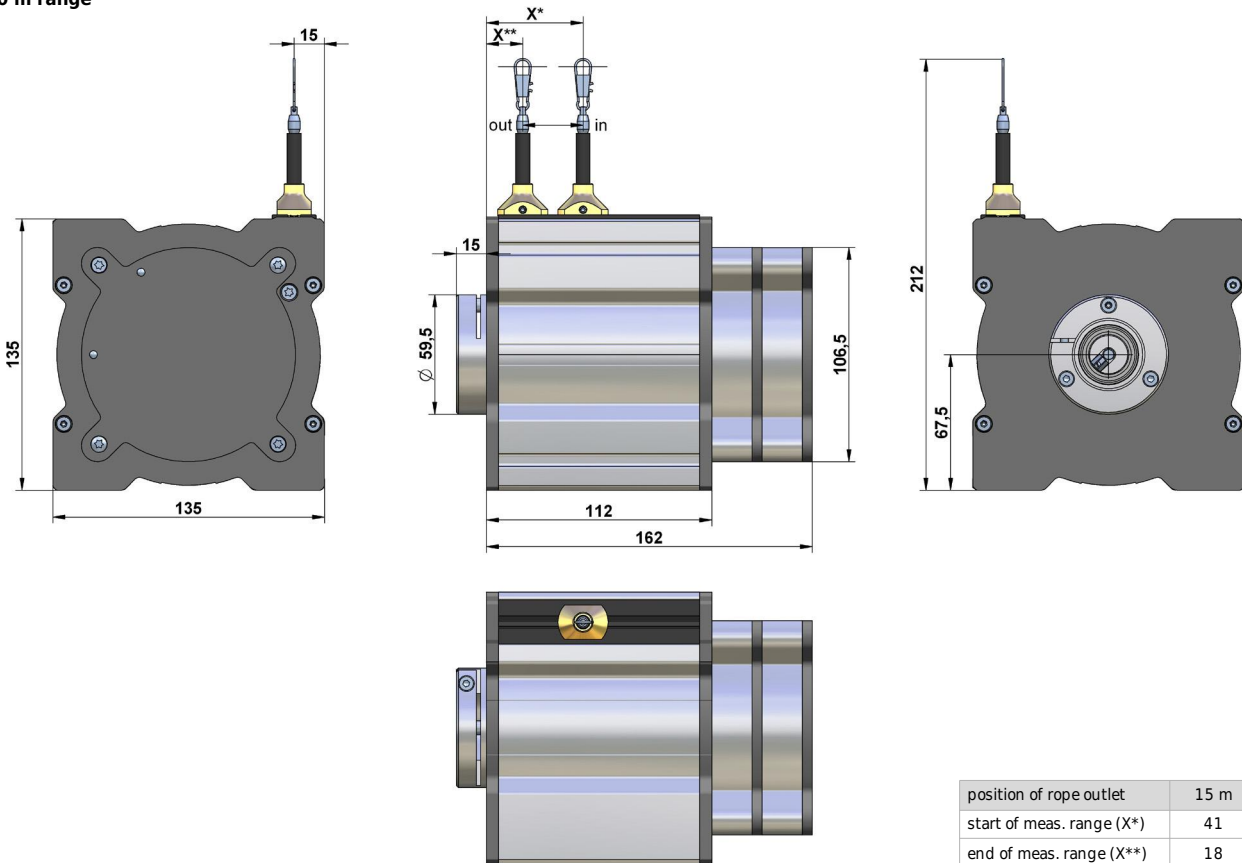

TECHNICAL DRAWING

25 - 30 m range

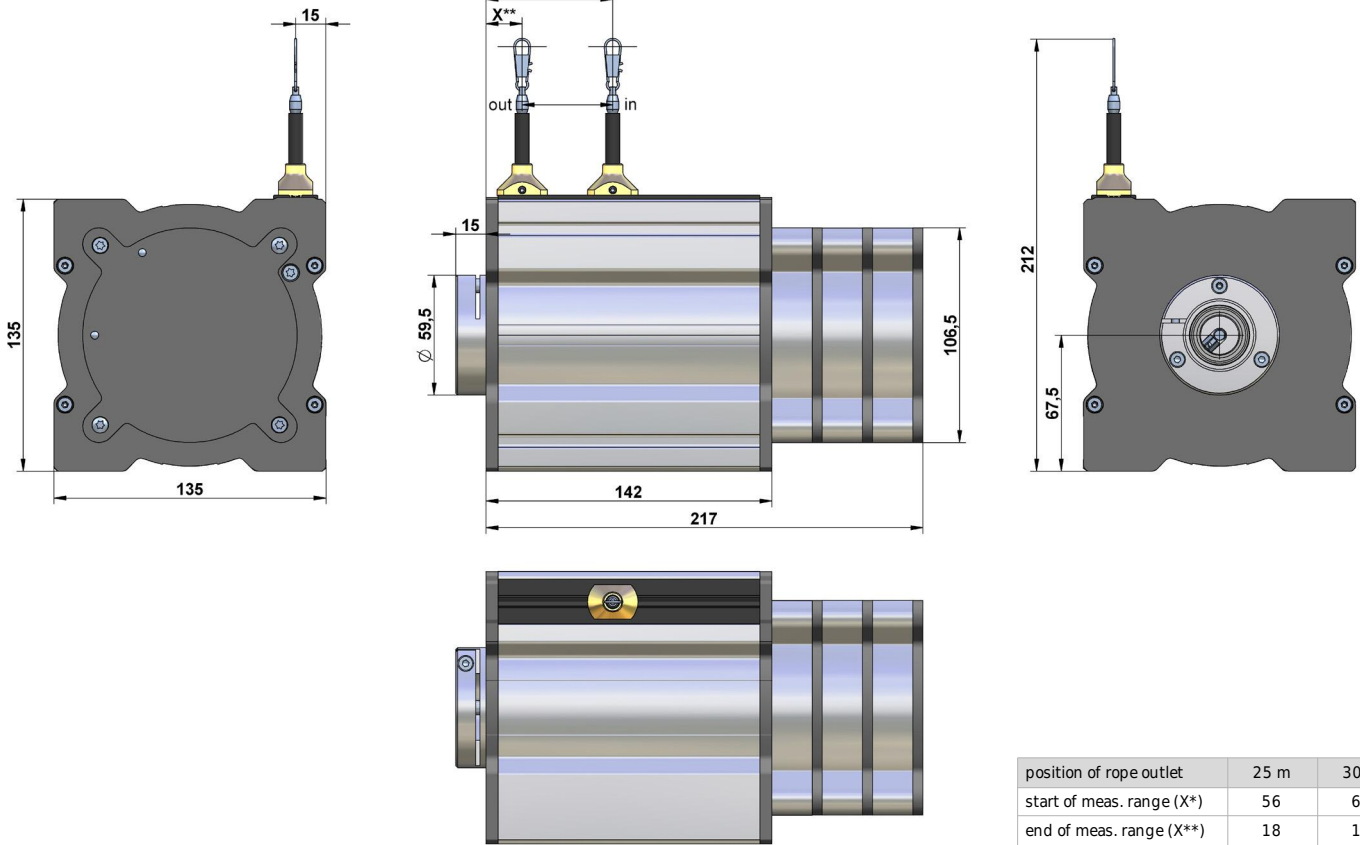

35 - 42,5 m range

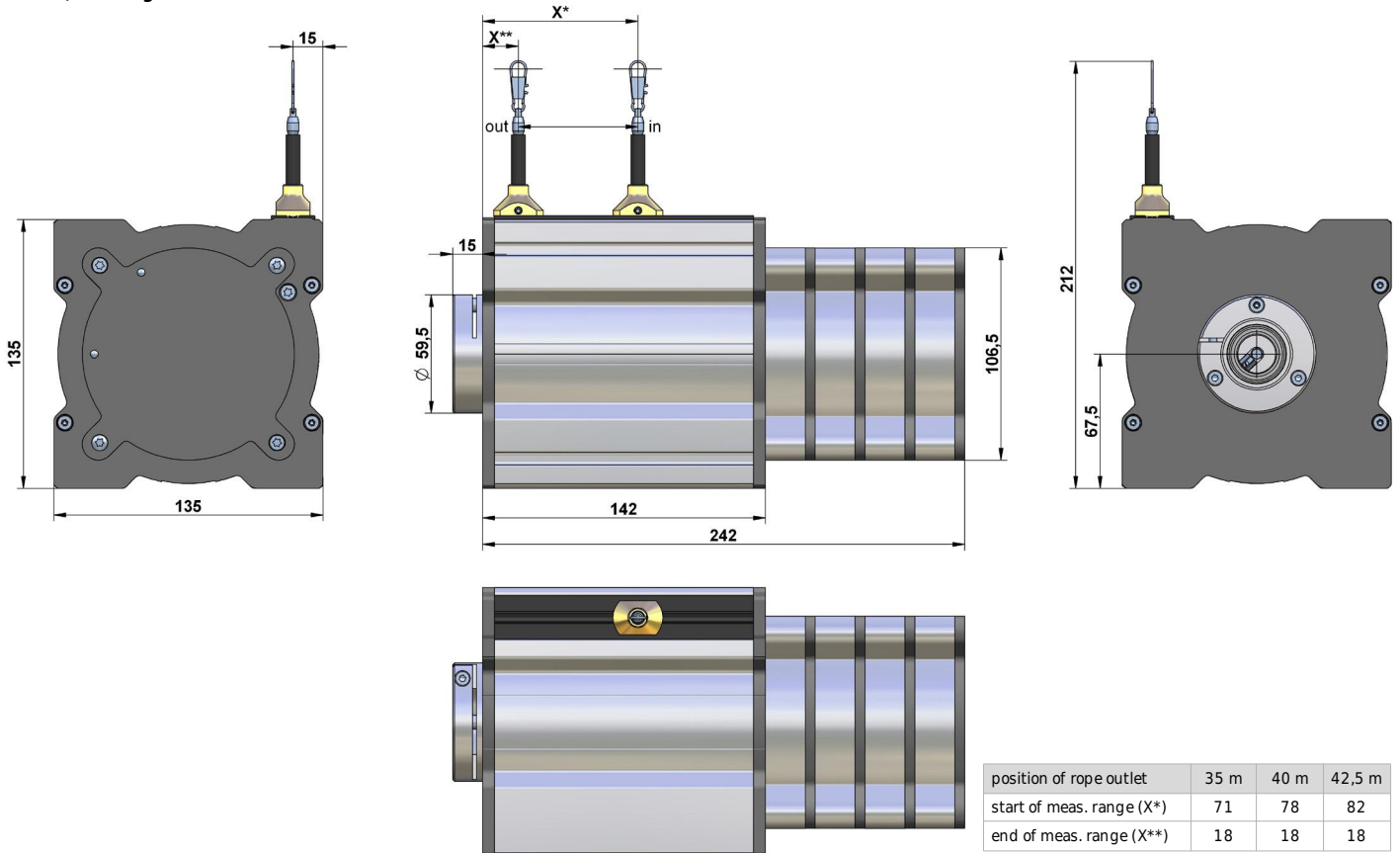

TECHNICAL DRAWING

dimensions for analogue output

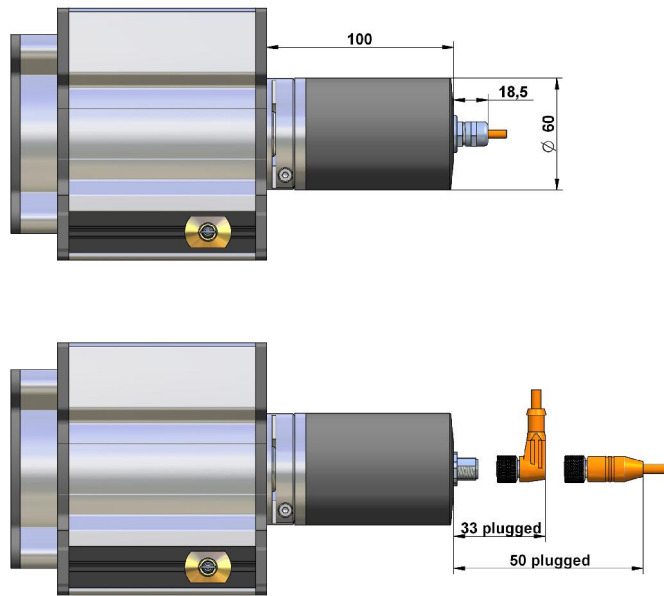

dimensions for digital output (incremental)

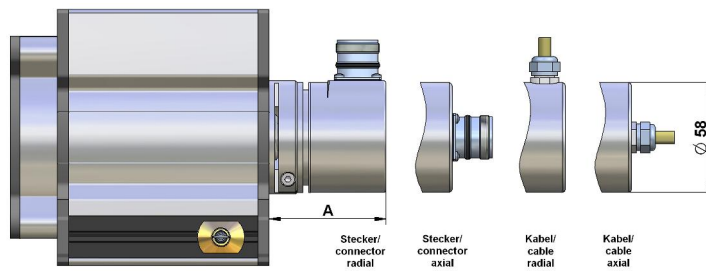

output	A
cable axial/ radial, connector axial	54,3
connector radial	64,3

MOUNTING OPTIONS

1. by using the grooves in the sensor housing

The included T-slot nuts can be easily inserted into the grooves of the sensor housing. The nuts have a metric thread M6.

Each sensor up to 20 m measurement range comes with 2 nuts, from 20 to 42,5 m for nuts are included.

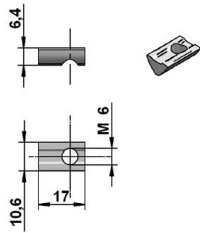

2. by angle clamp brackets

The angle clamp brackets feature a bore for M6 screws to fix it on a plate/ slab or a profile.

Each sensor up to 20 m measurement range comes with 2 brackets, from 20 to 42,5 m for brackets are included.

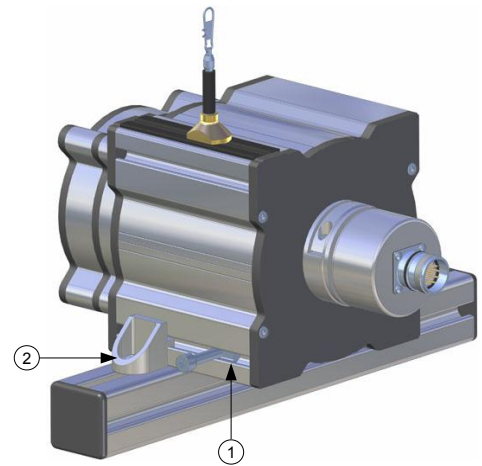
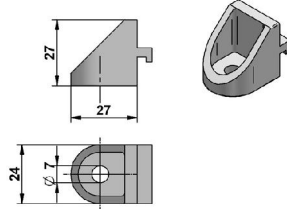

Important: The grooves of the sensor housing, the nuts and brackets are compatible to the aluminium building kit system from *item Industrietechnik GmbH* (www.item.info).

Position of the grooves:

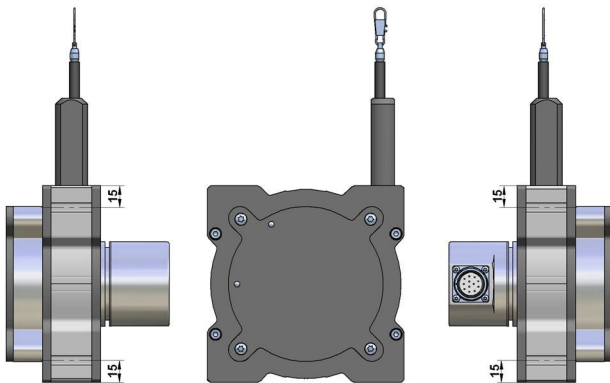

Mounting by using brackets:

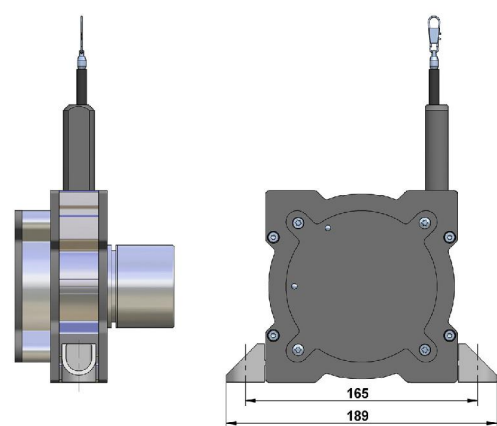

ENCODER ASSEMBLY BY EASY-CLAMP-MECHANISM

IMPORTANT: All incremental and absolute encoders must have a clamping flange (diameter 36mm), a shaft diameter of 10 mm and a shaft length of 10-20mm.

1.

Please mount the included coupling (1) on the shaft of the encoder and fix the set screw. Therefore you will need a hexagon screwdriver, size 2. Be careful that the dimension between contact surface of the encoder and the end of the cylinder bolt is 35mm.

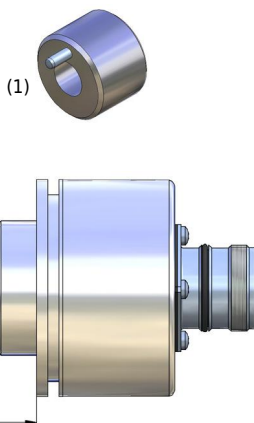

2.

Please mount the encoder into the easy-clamp-flange. The cylinder bolt must slip into the spring (2).

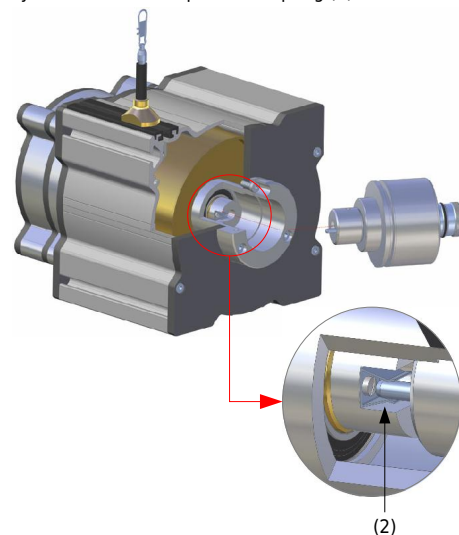

3.

By tightening the radial screw the encoder will be clamped and secured from twisting. Please use a hexagon screwdriver, size 3.

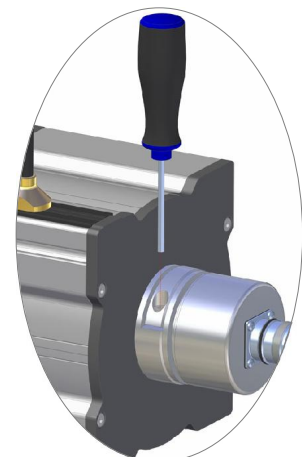

ANALOGUE OUTPUT

Potentiometer (voltage divider)

output	1 kOhm
supply voltage	max. 30 V
recommended cursor current	< 1 μ A
noise	depending on supply
working temperature	-20...+85 °C
temperature coefficient	\pm 0,0025 %/K

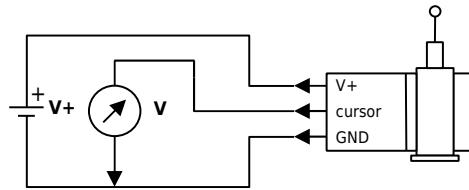

0...10 V voltage output

output	0...10 V, galvanically isolated, 4 conductors
supply voltage	12...30 VDC
max. current consumption	22,5 mA (unloaded)
output current	max. 10 mA, min. load 1 kOhm
dynamics	< 3 ms from 0...100 % and 100...0 %
noise	3 mV _{pp} typically, max. 37 mV _{pp}
inverse-polarity protection	yes, infinite
short-circuit proof	yes, permanent
working temperature	-20...+85 °C
temperature coefficient	0,0037 %/K
electromagnetic compatibility (EMC)	according to EN 61326-1:2006

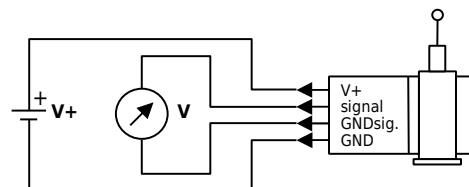

note: GNDsignal and GND may be connected in 3-wire system.

4...20 mA current output

output	4...20 mA, 2 conductors
voltage supply	12...30 VDC
output current	max. 50 mA in case of error
dynamics	< 1 ms from 0...100 % and 100...0 %
noise	0,03 mA _{pp} = 6 mV _{pp} at 200 Ohm
inverse-polarity protection	yes, infinite
working temperature	-20...+85 °C
temperature coefficient	0,0079 %/K
electromagnetic compatibility (EMC)	according to EN 61326-1:2006

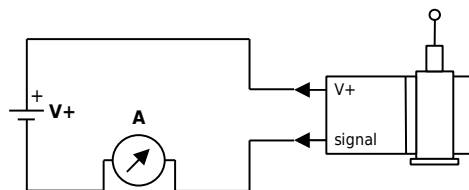

CONNECTION

cable output:

axial 2,0 metre standard, other cable length optional

type: TPE, flexible

diameter: \varnothing 4,5 mm

stranded wire: 0,25 mm²

temperature range: fixed installation -30...+85 °C, flexible installation -20...+85 °C

pin	wire colour	10 V	420 mA	1 kOhm
1	brown	V +	V +	V +
2	white	signal	n. c.	cursor
3	blue	GND	signal	GND
4	black	GND signal	n. c.	n. c.

4-pin M12 connector output (socket):

profile/ view on solder side of mating connector

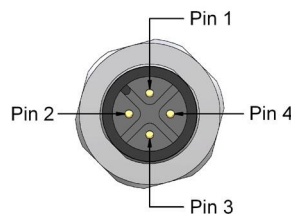

DIGITAL OUTPUT INCREMENTAL

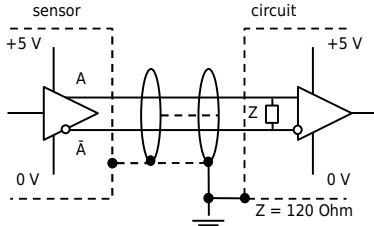
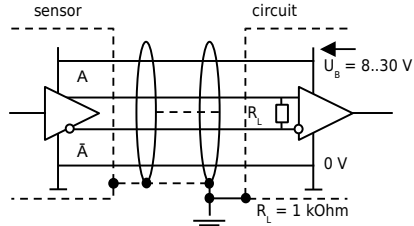
Electrical data	Linedriver L	Push Pull G
	RS422 (TTL-compatible)	
supply voltage	5 VDC, $\pm 5\%$	8...30 VDC
current consumption (no load)	typical 70 mA, max. 100 mA	typical 80 mA, max. 150 mA
max. load/ channel SX50	± 10 mA	± 30 mA
max. load/ channel SX80/ 120	± 20 mA	± 30 mA
max. pulse frequency SX50	125 kHz	100 kHz
max. pulse frequency SX80/ 120	300 kHz	300 kHz
min. signal level high	2,5 V	$U_B - 3$ V
max. signal level low	0,5 V	2,5 V
recommended circuit		
connection	connector 12-pin (counterclockwise), cable output 1,5 m	connector 12-pin (counterclockwise), cable output 1,5 m
protection class	IP65, optional IP67	IP65, optional IP67
max. cable length	up to 1000 m	up to 250 m

output signal

Pulses A and B are 90° phase-delayed (detection of direction). The Z-signal recurs with pulse distance Z and may be used as point of reference.

Diagramm shows the signal without inverted signals; timeline for return of rope.

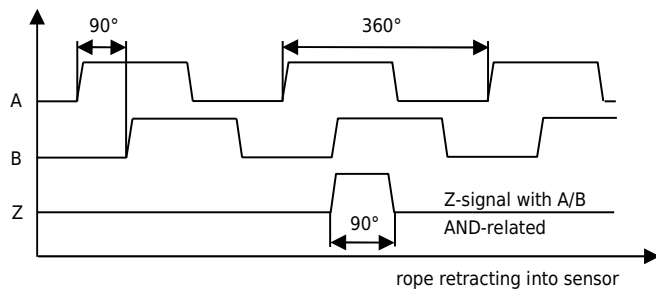

CONNECTION

Assignment

signal	0 V	U_B+	$0 V_{sens}^*$	$U_{Bsens}+^*$	A	A -	B	B -	Z	Z -	screen
12-pin connector	10	12	11	2	5	6	8	1	3	4	housing
wire colours	white	brown	black	violet	green	yellow	grey	pink	blue	red	housing

* For Linedriver L only. For long cable lengths it may occur that the operating voltage at the sensor does not suffice due to the output resistance. With the sensor lines $0V_{sens}$ and $+U_{Bsens}$ the operating voltage can be checked and, if necessary, be readjusted at the input connection.

12-pin connector output (socket)

Profile/ view on solder side of mating connector (only SX80/ SX120)

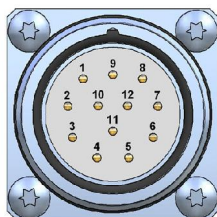

cable output

radial/ axial 1,5 metre standard
 other cable length optional
 type: UL2464/ 1061, LIYY, flexible
 outer diameter: \varnothing 6,5 mm
 stranded wire: 0,25 mm²
 temperature range: fixed installation -30...+80 °C,
 flexible installation -20...+80 °C

DIGITAL-ABSOLUTE / BUS SYSTEMS

output	Profibus-DP	CANopen	DeviceNet	EtherCAT	SSI
scalable resolution	yes	yes	yes	yes	no
standard resolution at range 8 m [pulses/ mm]	22,94	22,94	22,94	22,94	22,94
max. resolution at range 8 m [pulses/ mm]	183,5	183,5	22,94	183,5	-
standard resolution at range 10 - 42,5 m [pulses/ mm]	24,58	24,58	22,94	24,58	24,58
max. resolution at range 10 - 42,5 m [pulses/ mm]	196,61	196,61	22,94	196,61	-
supply voltage	10...30 VDC	10...30 VDC	10...30 VDC	10...30 VDC	10...30 VDC
current consumption (no load, at 24 VDC)	90 mA	65 mA	max. 290	90 mA	25 mA
protection class	IP65	IP65	IP65	IP65	IP65
protection class optional	IP67	IP67	-	IP67	IP67
working temperature	-20...+80 °C	-20...+80 °C	-20...+80 °C	-20...+80 °C	-20...+80 °C

Other encoder types (supply voltage, resolution, cable/ connector output) are available on request.

TECHNICAL DRAWING (ADDITION)

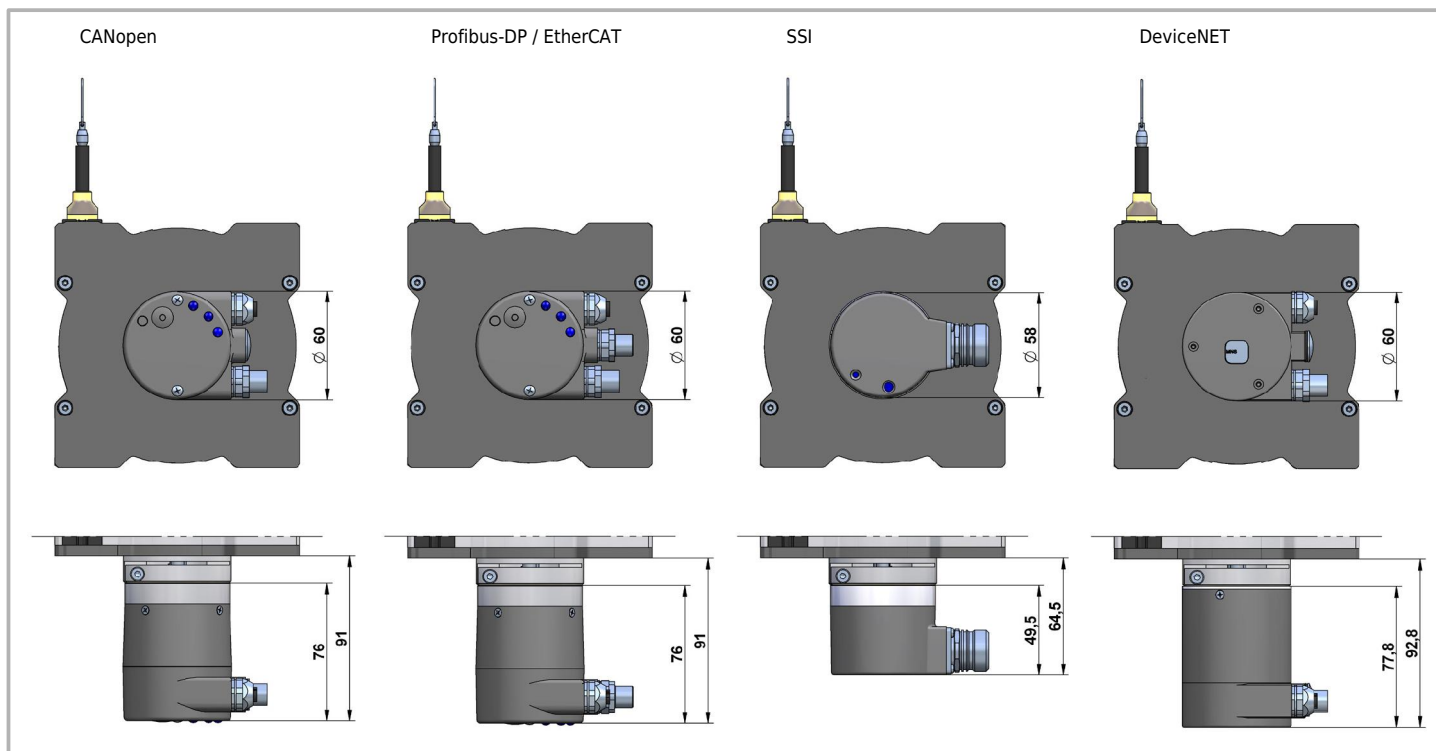

CONNECTION

encoder type	(other connection variants and protocols on request)
Profibus-DP	bus terminal cover, 3 x M12-connector (2 x male, 1 x female)
CANopen	removable bus terminal cover, 2 x M12-connector (1 x male, 1 x female)
DeviceNET	bus terminal cover, 2 x M12-connector (1 x male, 1 x female)
EtherCAT	bus terminal cover, 3 x M12-connector (1 x male, 2 x female)
SSI	12-pin M23-connector (pins counterclockwise), mating connector CON012-5

Please see encoder manual for detailed connection.

ACCESSORIES

Cable with mating connector M12 straight and angular - K4P (for analogue output potentiometer/ 10V/ 420A)

cable with straight connector:		cable with angular connector:	
K4P2M-S-M12	2 m	K4P2M-SW-M12	2 m
K4P5M-S-M12	5 m	K4P5M-SW-M12	5 m
K4P10M-S-M12	10 m	K4P10M-SW-M12	10 m



Mating connector M12 straight and angular for analogue output (field attachable connector)

straight connector:	D4-G-M12-S		
angular connector:	D4-W-M12-S		
protection class:	IP67	cable diameter:	ø 3...6,5 mm
temperature range:	-25...+90 °C	conductor:	max. 0,75 mm ²
mode of connection:	screw terminals		good chemical and oil resistance



Mating connector M23 for digital output and SSI - CON012-S

M23, straight, female connector, 12-pin clockwise (fits to male, counterclockwise connector)
metal housing

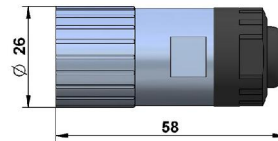

Deflection pulley - UR2

By using the deflection pulley, the rope can be looped around to e. g. measure in places that are difficult to access or to protect the sensor from inclined traction on the rope. Several pulleys may be used.

material: anodised aluminium, POM
mounting: by 2 hexagon socket or countersunk screws M6, vertical or horizontal mounting possible.

Ball bearings with special low temperature grease and RS-sealing.

Temperature range: -40...+80 °C.

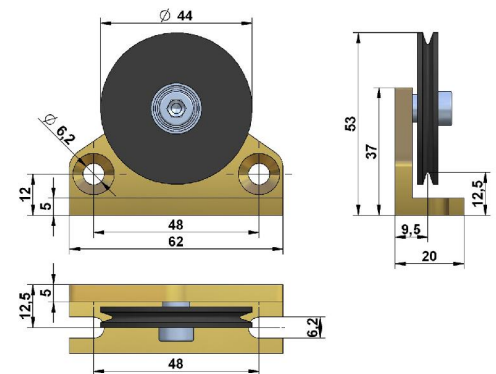
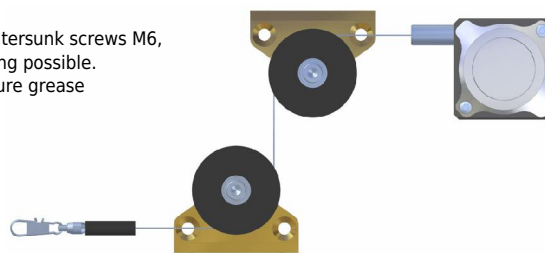

Rope extension - SV

For bridging a greater distance from the measuring target to the sensor a rope extension can be applied. The rope clip must not be guided over the deflection pulley.

Please specify the length needed in your order.
(example: rope extension of 250 mm = SV-250)



Magnetic clamp - MGG1

Use the magnetic clamp to quickly attach the rope to metallic objects without any assembly time. A rubber coating provides gentle contact (e. g. on varnished surfaces) and prevents from slipping due to vibration.

The magnet consists of a neodym core for an increased adhesive force of 260 N. The hook makes it easy to attach the rope clip (drill protection).

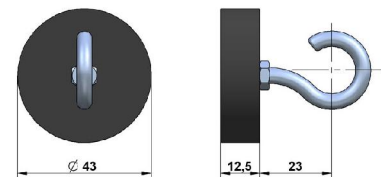

Digital distance and speed measurement - PAX

Use PAX display to visualise the covered distance or the speed (tacho sensor) of the position transducer. It enables a transmission of the measurement data to the computer via interface. The comparator allows a good-bad-evaluation (limit values function).

inputs:	incremental/ analogue, 2 independent counter, 1 tacho sensor
analogue output:	(0)4...20 mA, 0...10 V (plug in card)
serial interfaces:	RS485, RS232, DeviceNet (plug in card)
Protection class (front panel):	IP65
display:	6 digits
power supply:	11...36 VDC or 85...250 VAC



For further information please ask for the data sheet of the PAX display series.

INSTALLATION

- Mount the sensor at the designated place by using the fixing holes **before** extracting the rope and **before** attaching the rope to the measuring target.
- Open the rope clip (not with set screw M4) after the sensor is fully mounted and extract the measuring rope. Hook the rope clip on the measuring object and close the bracket of the clip. For your safety put a screw driver trough the clip to extract the rope.
- Check the track of the measuring target on **collision** with the sensor housing and on **exceeding** the specified measurement range. When installing the sensor make sure that the rubber stopper does not touch the rope outlet.
- Connect the electronics according to the sensor type. When laying the cables be careful not to under-run the minimal allowed bending radius of the cable (5 x cable diameter).
- The rope must be extracted from the sensor **vertically**. The maximum variation from the vertical is 3°. Avoid carefully extracting the rope at an inclination, since the durability of the instrument would shorten considerably. If it is not possible to keep the limit of 3°, a deflection pulley has to be used.
- The measuring range/ the **zero point** begins after approximately 2 mm extracted rope. The mechanical reserve at the end of the measuring range is about 20 mm.
- When mounting outdoors protect the sensor and the rope from ice-formation at temperatures below 0 °C.
- Lay the rope preferably in corners or guarded in guidings to prevent pollution or accidental touch.
- When operating the sensor, take care **not to let** the rope **snap back** by mistake or extract the rope **over** the specified **measurement range**, as this might destroy the sensor.
- **Maintenance:** These instruments are maintenance-free. If however, the rope is soiled due to adverse environmental conditions, it should be cleaned with a cloth drenched in resin-free machine oil.



WARNING NOTICES

- Don't let the rope snap back. If the rope is retracted freely, this may lead to injuries (whiplash effect) and the instrument may be damaged. Caution when unhooking and retracting the rope into the sensor.
- Never exceed the specified measurement range when extracting the rope!
- Don't try to open the instrument. The stored energy of the spring drive may lead to injuries when being mishandled.
- Don't touch the rope when operating the sensor.
- Avoid guiding the rope over edges or corners. Use a deflection pulley instead.
- Don't operate the sensor if the rope is buckled or damaged. A ripping of the rope may lead to injuries or damaging the sensor.



ORDER CODE DRAW WIRE MECHANICS (FOR ENCODER ASSEMBLY)

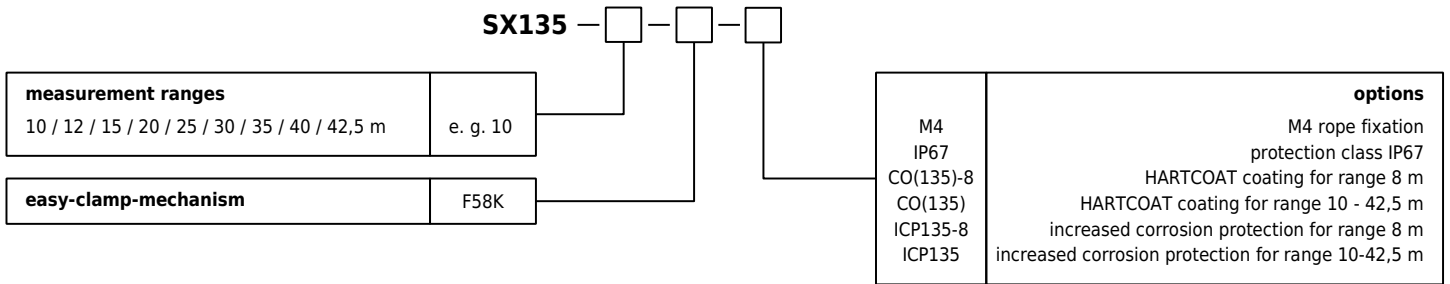

ORDER CODE ANALOGUE OUTPUT

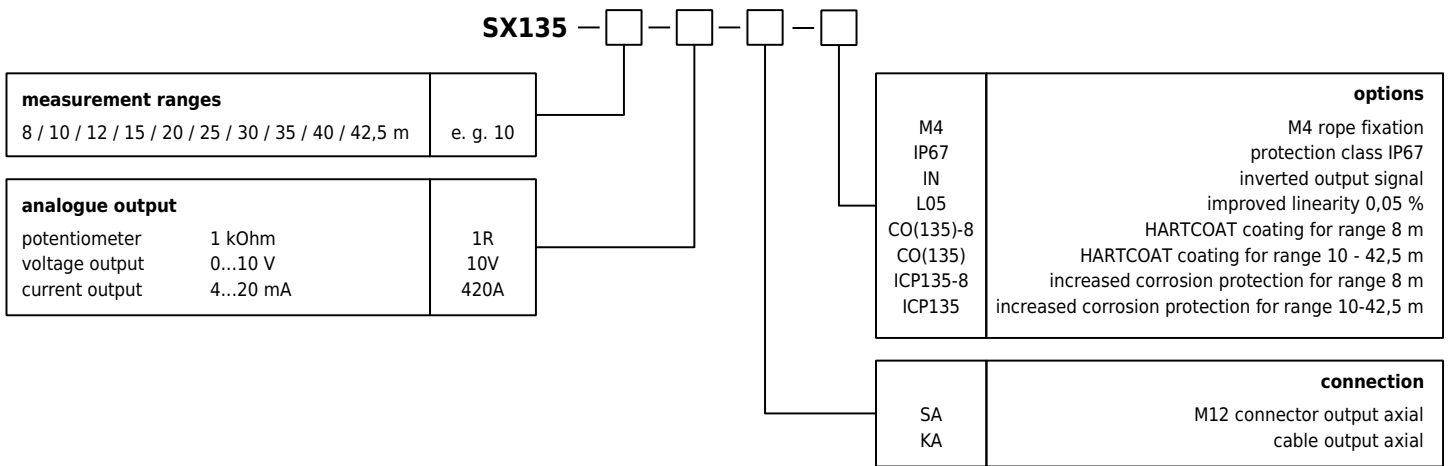

ORDER CODE DIGITAL / DIGITAL-ABSOLUTE / BUS SYSTEMS

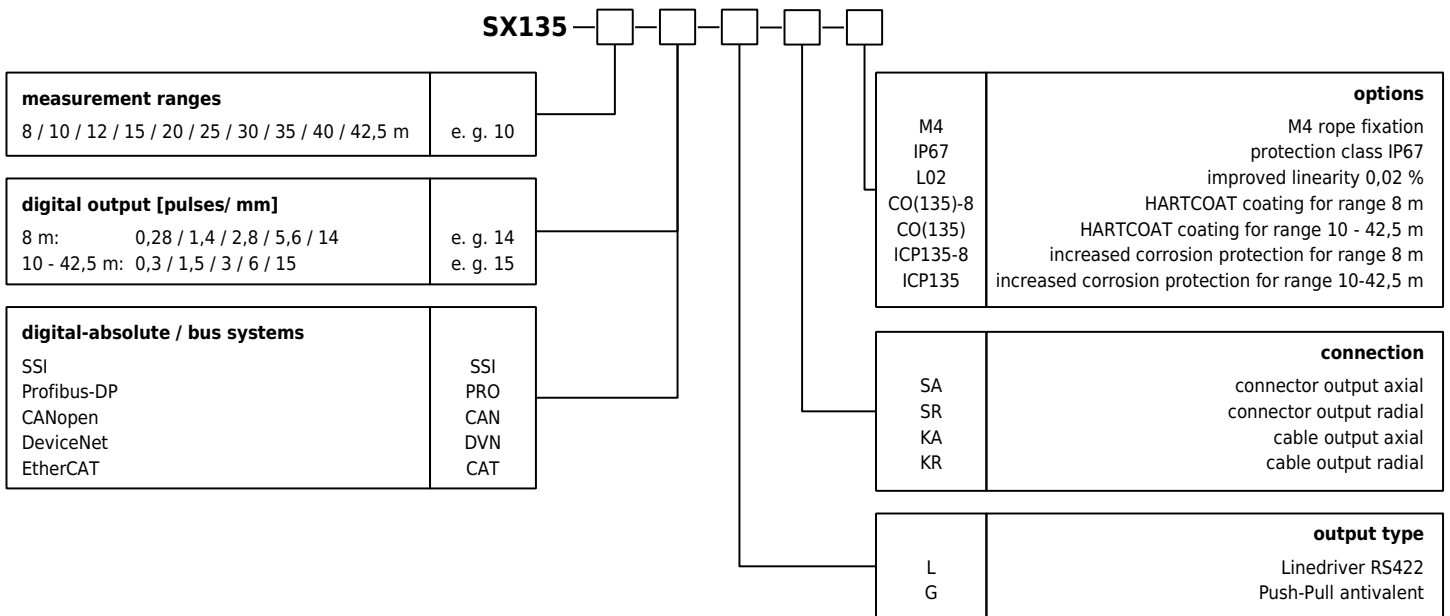

We reserve the right to alter the specification without prior notice.

WayCon Positionsmesstechnik GmbH

email: info@waycon.de

internet: www.waycon.de

Head Office

Mehlbeerenstr. 4

82024 Taufkirchen

Tel. +49 (0)89 67 97 13-0

Fax +49 (0)89 67 97 13-250

Office Köln

Auf der Pehle 1

50321 Brühl

Tel. +49 (0)2232 56 79 44

Fax +49 (0)2232 56 79 45